

## Werkvoorbereiding 3D printen

Naam	Rick Koelewijn
Klas	MTD3A4
Project	Koptelefoon
Datum	21-06-2017
Bijlagen	Documenten lasersnijden
Telefoonnummer	06 53 69 7882



Tekening/screenshot

Wat                      Wanneer                      Geschatte uren

Benodigd gereedschap:			
Benodigd gereedschap:	3D printer	22-06-2017 - 30-06-2017	5
Benodigd gereedschap:			
Benodigd gereedschap:			
Benodigd Materiaal:	PLA	22-06-2017 - 30-06-2017	4x
Benodigd Materiaal:			
Benodigd Materiaal:			
Totaal uren			5

Handtekening docent

Tekeningen bijlagen	Tekening BOA
Tekeningen bijlagen	Tekening BOB
Tekeningen bijlagen	
Tekeningen bijlagen	

Handtekening werkplaats

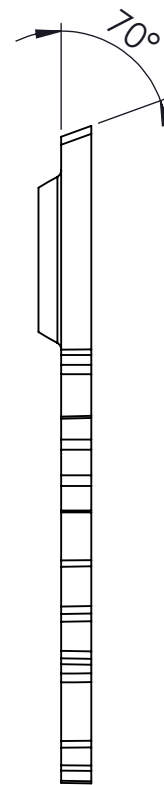
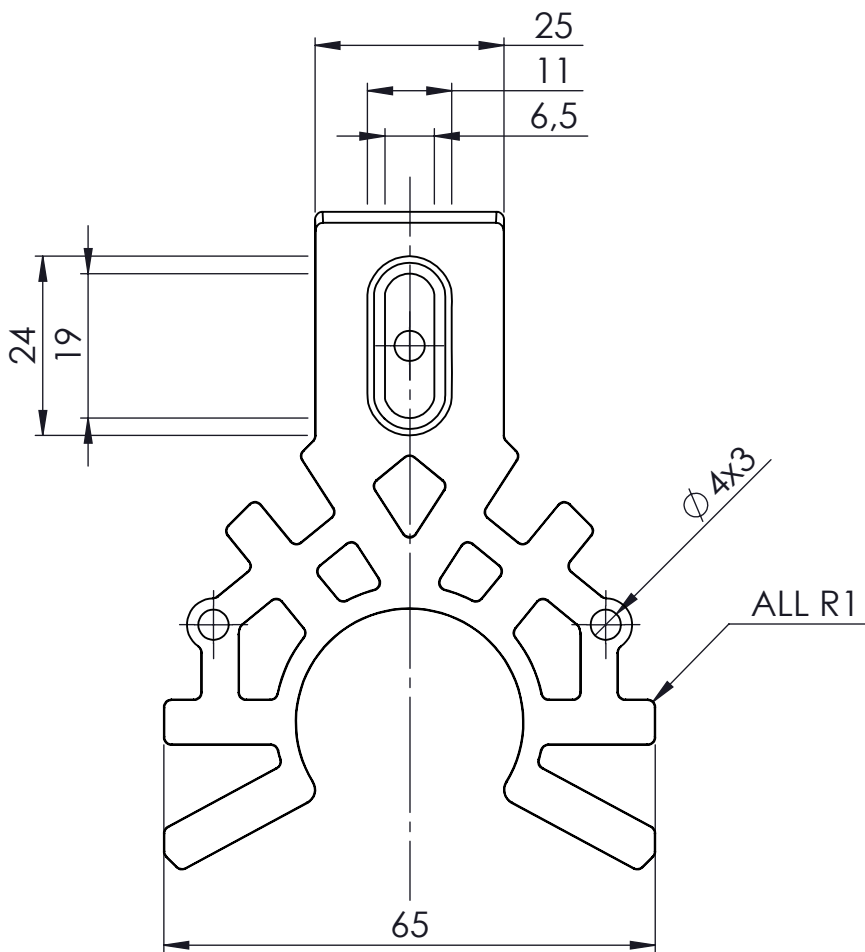
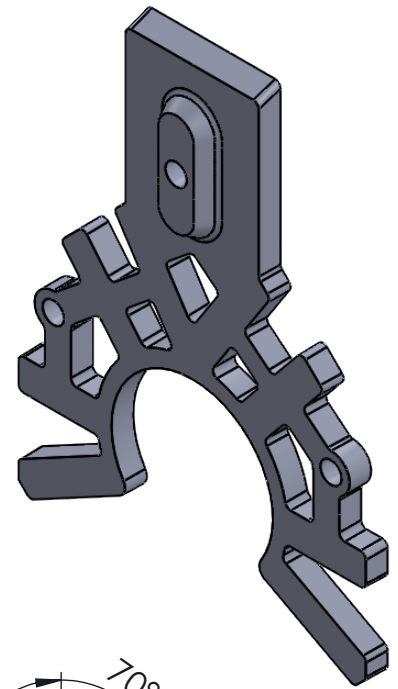
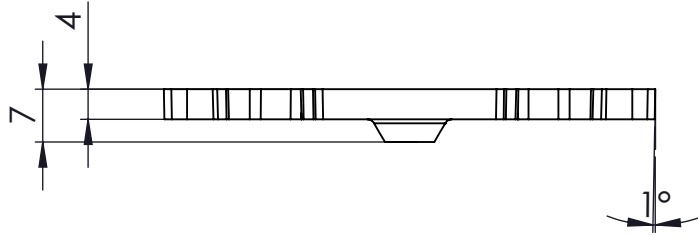

Opp. ruwheid (zie NEN 3634)	Maattoleranties NEN-ISO 2768-	MATERIAAL: PLA	Vorm- en plaatstol. (zie NEN-ISO11010)
	SCHAAL: 1:1	GETEKEND: Rick Koelewijn	OPMERKING:
	MAATEENHEID: mm	AFDELING: MTD3A4-IPO	
	DATUM: 22-6-2017	GEZIEN:	
		BOA	NUMMER: 1
			A4

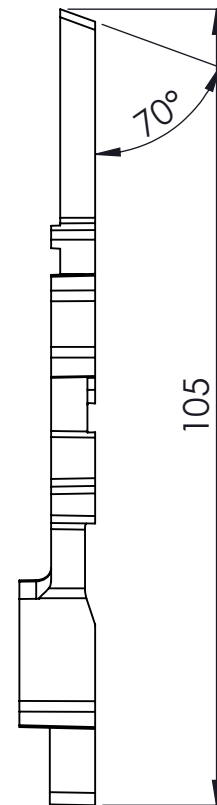
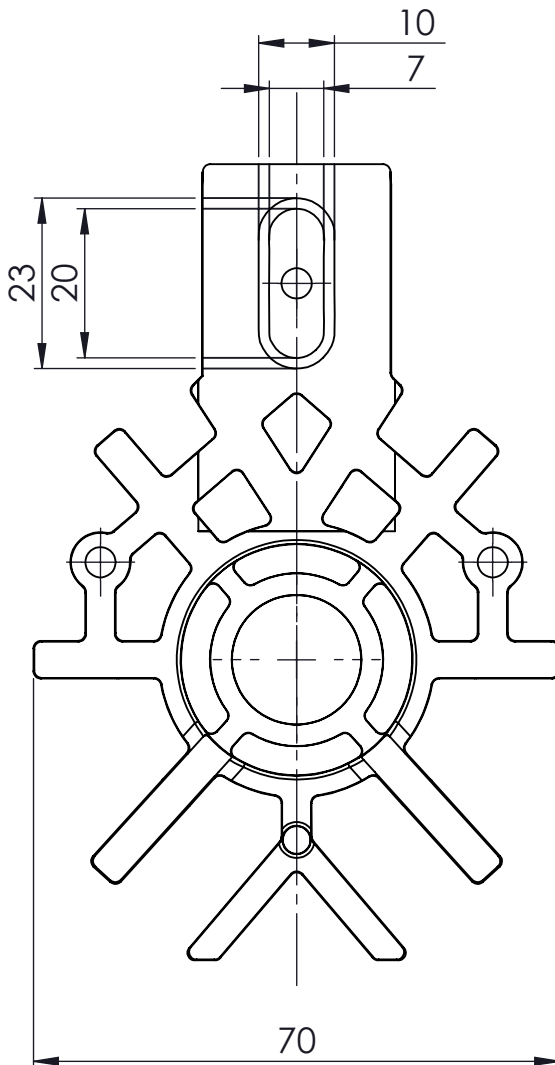
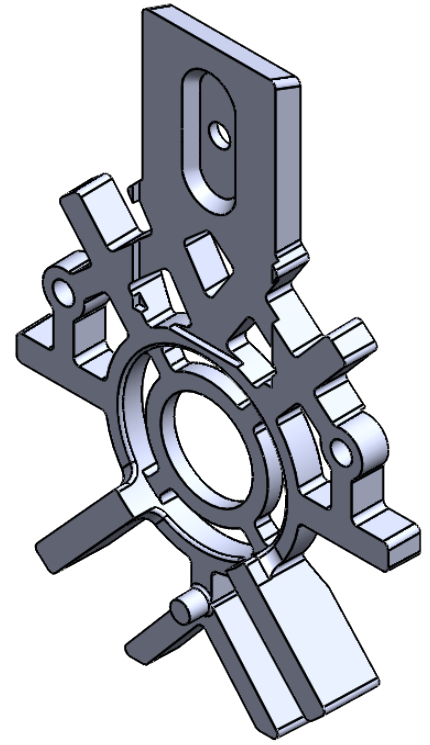
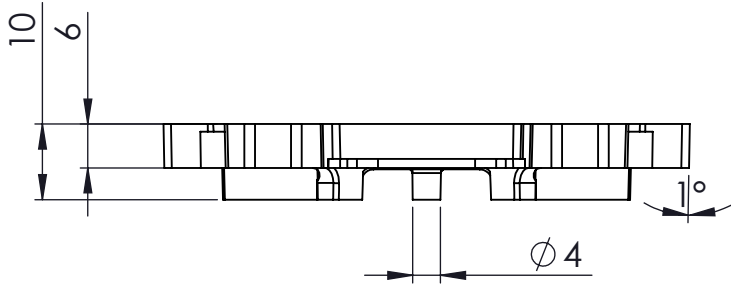

Opp. ruwheid (zie NEN 3634)	Maattoleranties NEN-ISO 2768-	MATERIAAL: PLA	Vorm- en plaatstol. (zie NEN-ISO11010)
	SCHAAL: 1:1	GETEKEND: Rick Koelewijn	OPMERKING:
	MAATEENHEID: mm	AFDELING: MTD3A4-IPO	
	DATUM: 22-6-2017	GEZIEN:	
		BOB	NUMMER: 2
			A4